



**VIDEO
PRODUCTS
INCORPORATED**

1275 Danner Drive Aurora, Ohio 44202
Tel: 330-562-2622 Fax: 330-562-1999
www.vpi.us

ST-WLHDMI-L-30M

ST-WLHDMI-R-30M

Local and Remote HDMI Wireless Extender Installation and Operation Manual



Local and Remote Units are each sold separately

COPYRIGHT

Copyright © 2009 by Video Products Incorporated. All rights reserved. No part of this publication may be reproduced, stored in a retrieval system, or transmitted, in any form or by any means, electronic, mechanical, photocopying, recording, or otherwise, without the prior written consent of Video Products Incorporated, 1275 Danner Drive, Aurora, Ohio 44202

CHANGES

The material in this manual is for information only and is subject to change without notice. Video Products Incorporated reserves the right to make changes in the product design without reservation and without notification to its users.

TABLE OF CONTENTS

Introduction.....	1
Materials.....	2
Operation Controls and Functions	3
Local Unit	3
Front Panel	3
Side Panel.....	4
Remote Unit	4
Front Panel	4
Side Panel.....	5
Remote Control	5
Connections.....	6
Technical Specifications.....	7
Troubleshooting.....	7
Warranty Information.....	8

TABLE OF FIGURES

Figure 1- Front panel on Local Unit	3
Figure 2- Side panel on Local Unit.....	4
Figure 3- Front panel on Remote Unit.....	4
Figure 4- Side panel on Remote Unit.....	5
Figure 5- Remote Controls.....	5
Figure 6-Operating range of remotes.....	5
Figure 7- Cable Connections	6

INTRODUCTION

The ST-WLHDMI-L/R-30M wireless HDMI transmitter (Local Unit) and receiver (Remote Unit) uses 5GHz radio technology to deliver uncompressed high definition video and audio up to 98 ft. (30 m) in open field, while maintaining superb, wire-equivalent quality and robustness. HDMI video from up to 3 sources can be transmitted to one or many receivers.

Features:

- Crisp and clear 1080p resolution at 98 feet (30 meters) in open field, depending on environment.
- Transmits through thin walls or wooden doors.
- Supports both Unicast Mode (One-to-One, HDCP/Non-HDCP signal) and Broadcast Mode (One-to-Many, Non-HDCP signal only) modes.
- Local Unit:
 - Input: Three female HDMI Type A connectors.
- Remote Unit:
 - Output: One female HDMI Type A connector.
- Supports 480i, 480p, 576i, 576p, 720p, 1080i and 1080p resolution for HDTV displays.
 - 1080p resolution at 24 or 30 Hz, all others at 60 Hz.
- Wireless frequency range: 4.9 ~ 5.9 GHz.
- Compliant with HDMI 1.2, HDCP 1.1 and DVI 1.0 standards.
- Supports the DDC2B standard for all input ports.
- Includes infrared remote controls for local unit and remote unit.

MATERIALS

Materials supplied with Local Unit:

- ST-WLHDMI-L-30M Wireless HDMI Local Unit
- 100-240VAC, 50 or 60Hz-5VDC/2.6A AC Adapter
- CR-67 Remote for Local Unit
- Stand
- 4-Stick-on rubber feet
- This manual

Materials supplied with Remote Unit:

- ST-WLHDMI-R-30M Wireless HDMI Remote Unit
- 100-240VAC, 50 or 60Hz-5VDC/2.6A AC Adapter
- CR-68 Remote for Remote Unit
- Stand
- 4-Stick-on rubber feet
- This manual

Materials *Not* supplied but **REQUIRED**:

HDMI-xx-MM cables for connecting Local Unit and Remote Unit to video source and display (xx = 3,6,9,14,20,30,50, 75, or 100 feet)

Cables can be purchased from Video Products Inc by calling (800) 626-7801 in the US and Canada or (330) 562-2622 (worldwide).

OPERATION CONTROLS AND FUNCTIONS

Local Unit

Front Panel

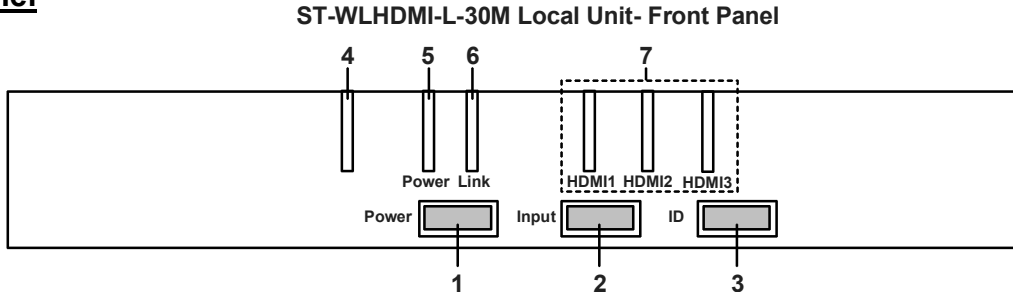

Figure 1- Front panel on Local Unit

1. **Power:** Press to turn ON/OFF the system.
2. **Input:** Press to select input source (1/2/3).
3. **ID:** Press to use for pairing the system or changing operating mode

Pairing

Pairing is performed to establish a wireless link between the Local Unit and Remote Unit. The systems are paired at the factory so only press the “ID” buttons if the system doesn’t link up properly on their own.

Press the Local Unit “ID” button for 4 seconds, then the Remote Unit “ID” button for 4 seconds to pair the system.

Unicast vs. Broadcast Modes

The ST-WLHDMI-30M can be set to transmit a video signal to one Remote Unit (Unicast Mode) or multiple Remote Units (Broadcast Mode).

Press the ID button for more than 15 sec. to switch to a different mode (Broadcast/Unicast).

- Green power LED means Unicast mode is set (factory default)
- Red power LED means Broadcast Mode is set.

Note: It is not necessary to press the Local Unit and Remote Unit’s ID button at the same time.

Broadcast Mode Limitations

Note: Due to the nature of the transmission, the Broadcast mode has no uplink and therefore no bi-directional communication between Local Unit and Remote Unit. This results in the following limitations:

- **HDCP protected content will not be transmitted.**
- **CEC and EDID repeater functionalities are not supported.**
- **Broadcast mode is not HDCP compliant.**

4. **IR sensor:** For receiving the IR signal from the remote control.
5. **Power LED:** The LED will illuminate when power is ON.
6. **Link LED:** When the devices are searching for each other, the Link LED will flash rapidly. While a link is being established, the Link LED will flash slowly. Once the link is established the Link LED stays ON solid.
7. **Input indicator:** The LED will illuminate to indicate which input source is selected.

Side Panel

8. **HDMI 1/2/3 Inputs:** For connecting to the HDMI output of your source equipment such as DVD player or set-top-box. Up to 3 different HDMI sources can be connected.
9. **Power:** Plug the 5VDC power supply into this unit and connect the adapter to AC wall outlet.

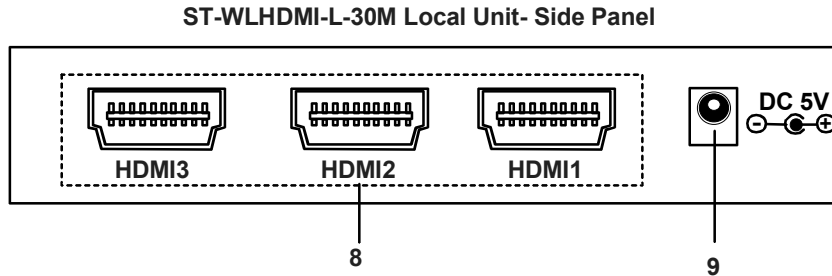

Figure 2- Side panel on Local Unit

Remote Unit

Front Panel

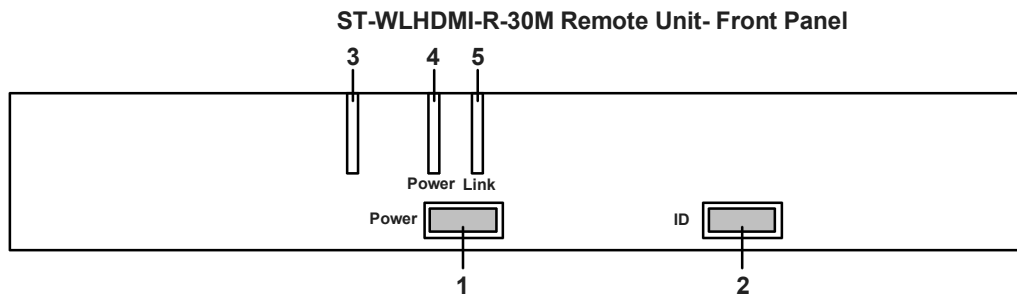

Figure 3- Front panel on Remote Unit

1. **Power:** Press to turn ON/OFF the system.
2. **ID:** Press to use for pairing the system or changing operating mode

Pairing

Pairing is performed to establish a wireless link between the Local Unit and Remote Unit. The systems are paired at the factory so only press the “ID” buttons if the system doesn’t link up properly on their own.

Press the Local Unit “ID” button for 4 seconds, then the Remote Unit “ID” button for 4 seconds to pair the system.

Unicast vs. Broadcast Modes

The ST-WLHDMI-30M can be set to transmit a video signal to one Remote Unit (Unicast Mode) or multiple Remote Units (Broadcast Mode).

Press the ID button for more than 15 sec. to switch to a different mode (Broadcast/Unicast).

- Green power LED means Unicast Mode is set (factory default)
- Red power LED means Broadcast Mode is set.

Note: It is not necessary to press the Local Unit and Remote Unit's ID button at the same time.

Note: See also “Broadcast Mode Limitations” on previous page.

3. **IR sensor:** For receiving the IR signal from the remote control.
4. **Power LED:** The LED will illuminate when power is ON.
5. **Link LED:** When the devices are searching for each other, the Link LED will flash rapidly. While a link is being established, the Link LED will flash slowly. Once a link is established the Link LED will stay ON solid.

Side Panel

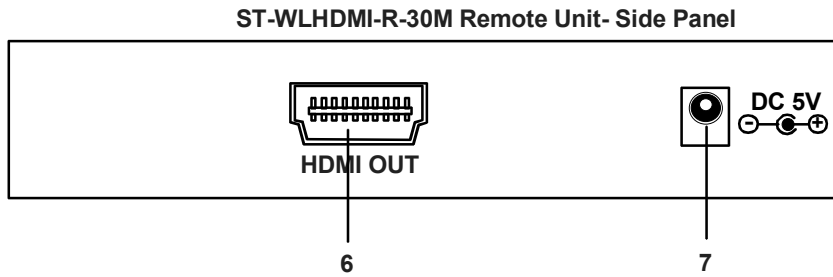

Figure 4- Side panel on Remote Unit

- 6. **HDMI Input:** For connecting to the HDMI input of your display.
- 7. **Power:** Plug the 5VDC power supply into this unit and connect the adapter to AC wall outlet.

Remote Control

- 1. **Power:** Press to turn ON/OFF the device (Local Unit or Remote Unit)
- 2. **ID:** used the same as described in “Local Unit Side” or “Remote Unit Side” sections
- 3. **1~3:** Input source selection

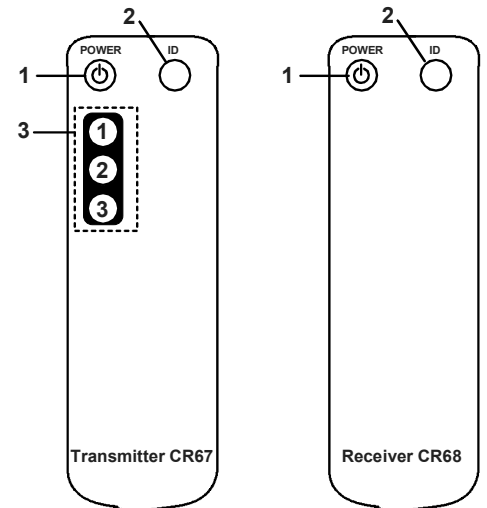

Figure 5- Remote Controls

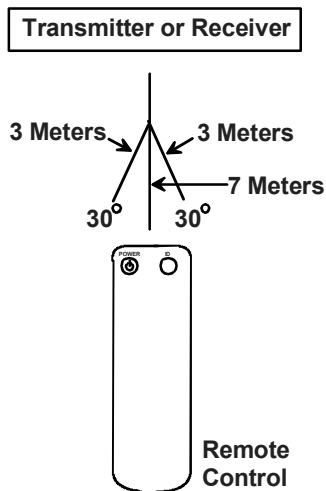
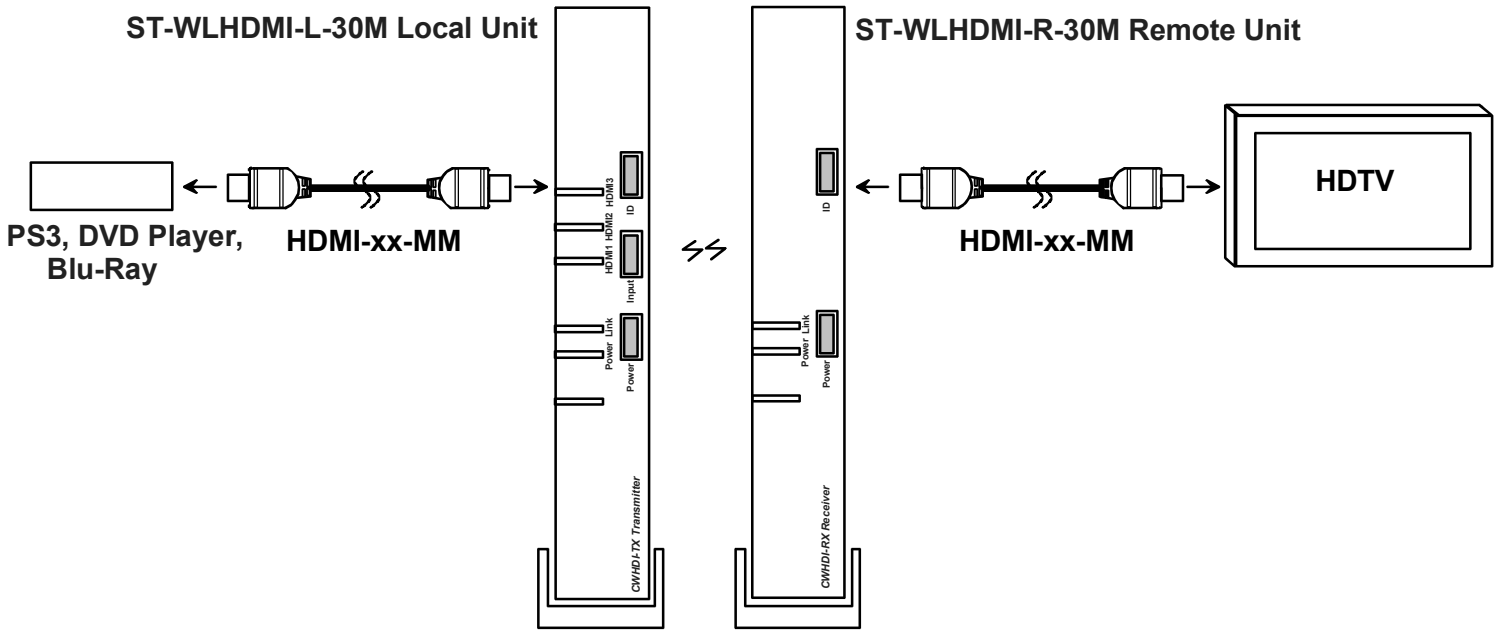

Figure 6-Operating range of remotes

CONNECTIONS

UNICAST Configuration



BROADCAST Configuration

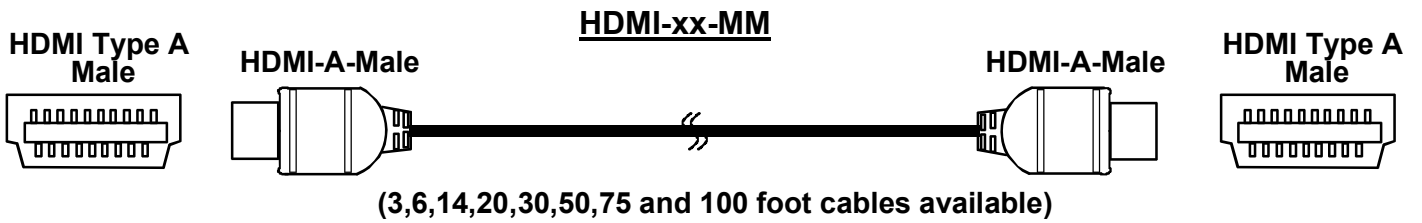
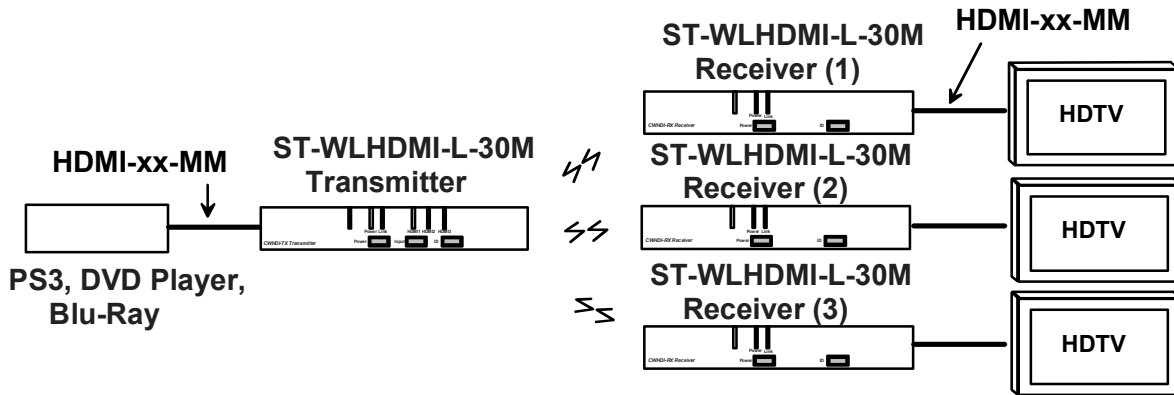

Figure 7- Cable Connections

TECHNICAL SPECIFICATIONS

Video Data Rate	1.5Gbps
Frequencies Supported	4.9~5.9GHz
Bandwidth	20MHz
Wireless Range	15-30 meters open field
Operating Temperature	0°C ~ 40°C
Resolution	480i/p, 576i/p, 720p, 1080i @60Hz, 1080p @24/30Hz, VGA @60/72Hz, SVGA @60/72Hz, XGA@60/70Hz
Video Connectors	Inputs – 3 HDMI Type A Female (Local Unit) Output – 1 HDMI Type A Female (Remote Unit)
Power Consumption	5VDC, Local Unit: 1.6A, Remote Unit: 1.3A
Power Supply	100-240VAC, 50 or 60Hz-5VDC/2.6A AC Adapter
Weight	Local Unit: 0.6 lb., Remote Unit: 0.6 lb.
Size (In.) WxDxH	6.4 x 6.5 x 1.3 inches
Chassis Material	Plastic
Approvals	UL, (c)UL (Power Adapter Only) CE, RoHS

TROUBLESHOOTING

Each and every piece of every product produced by Video Products Inc is 100% tested to exacting specifications. We make every effort to insure trouble-free installation and operation of our products. If problems are experienced while installing this product, please look over the troubleshooting chart below to see if perhaps we can answer any questions that arise. If the answer is not found in the chart, please check the FAQs (Frequently Asked Questions) at our website at <http://www.vpi.us> or contact us directly for help at 1-800-626-7801 in US & Canada or 1-330-562-2622 worldwide. We will be happy to assist in any way we can.

Problem	Solution
Power LED does not illuminate when power is ON.	<ul style="list-style-type: none"> • Check to see if the correct AC adapter is being used- • 5VDC 2.6A • Check all power connections are plugged-in correctly • Push the power buttons to turn ON Local Unit and Remote Unit.
After powering on Local Unit and Remote Unit, the Link LED is flashing rapidly / slowly without image.	<ul style="list-style-type: none"> • The Link LED will flash while the unit is pairing or learning. After pairing is complete and the Local Unit and Remote Unit are linked, the LED will illuminate solid. • If the LED keeps flashing rapidly for more than 3 minutes, try pairing the devices by pushing the ID buttons on each unit for 4 seconds. • If the LED keeps flashing slowly for more than 3 minutes, check the Local Unit input selection, make sure the video source is ON and make sure the display is ON.
The Link LED is illuminating consistently without image display or unexpected image display.	<ul style="list-style-type: none"> • Check if the video source's timing is supported by the device. The ST-WLHDMI-30M supports up to 1080i @ 60Hz and 1080p @ 24/30Hz. Make sure the video source is sending acceptable timing to the extender and display. Also make sure the display can accept that timing. • Check if both the video source and display are HDCP/CEC compliant. • Check if display mode is properly selected. • Check if both the video source and display cables are securely connected
Input LED will not illuminate	When linking the first time, the input LED will not illuminate unless the display is connected and powered ON. Make sure the display is connected and powered.
Local Unit and Remote Unit have different colors on their Power LED	Local Unit and Remote Unit are in different operating modes. Green indicates Unicast Mode, Red indicates Broadcast Mode. Press the ID button of the unit that is set for the wrong mode for 15 seconds to change it to the desired mode.

WARRANTY INFORMATION

The warranty period on this product (parts and labor) is one (1) year from the date of purchase. Please contact Video Products Incorporated at **(800) 626-7801** (800-RGB-TECH) or **(330) 562-2622** or visit our website at <http://www.vpi.us> for information regarding repairs and/or returns. A return authorization number is required for all repairs/returns.

PRODUCT

SERIAL NO.: _____

DATE: _____ **INSPECTED BY:** _____

MAN007 Rev. 10/28/09